

Detalhe 2 - CT - Canteiro de Travessia

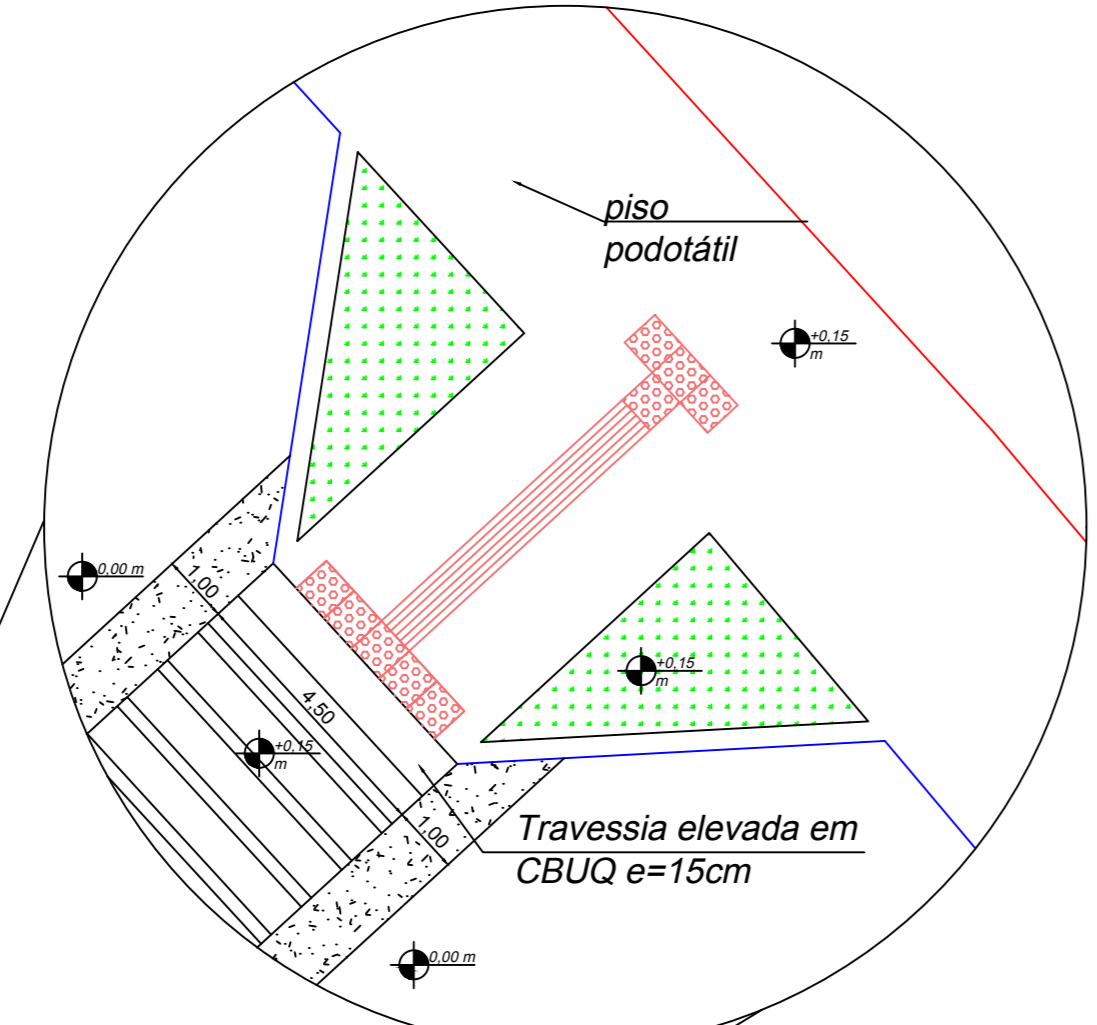

Detalhe 1- Faixa de sinalização e canteiro

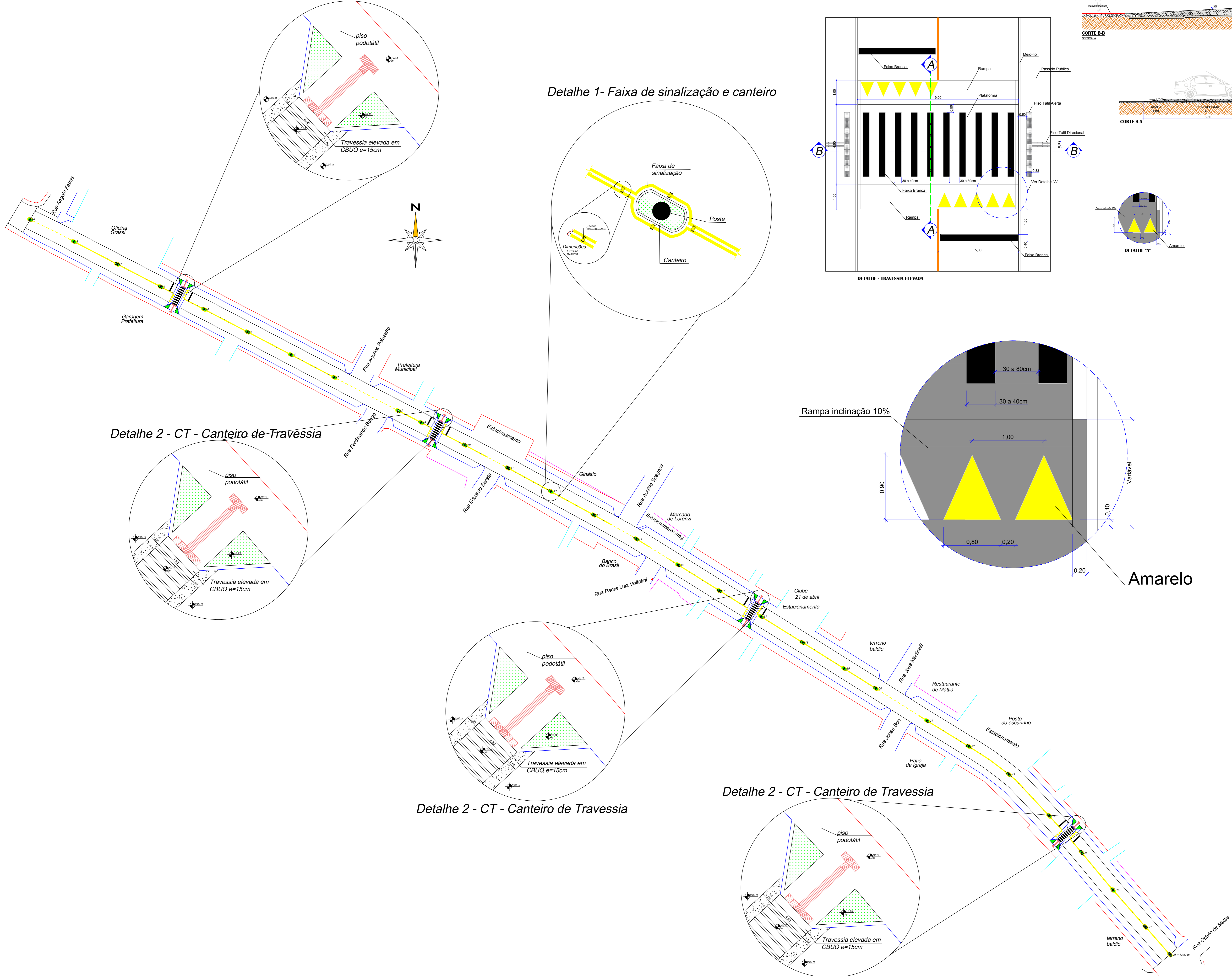
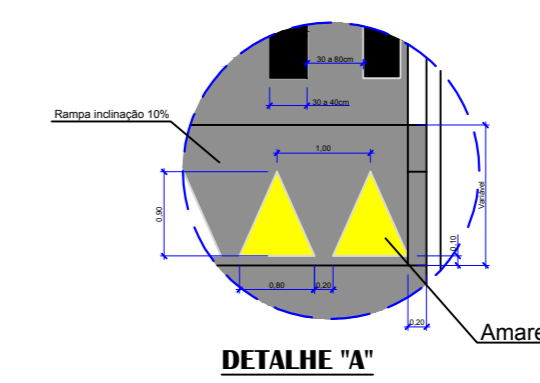
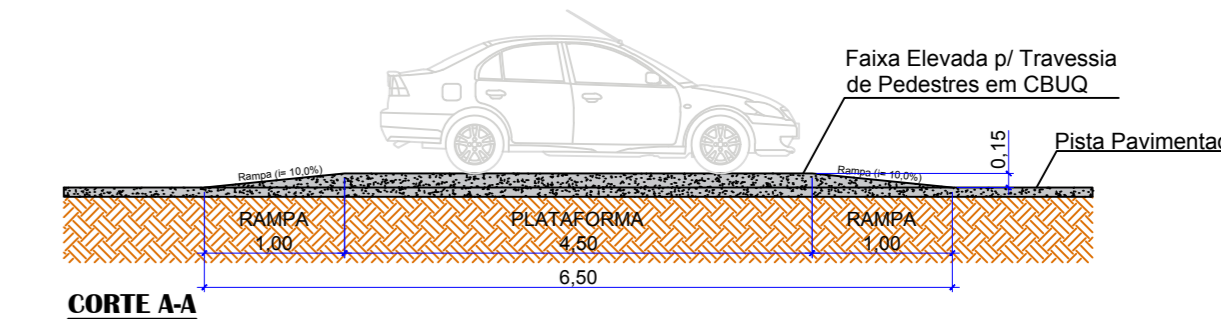
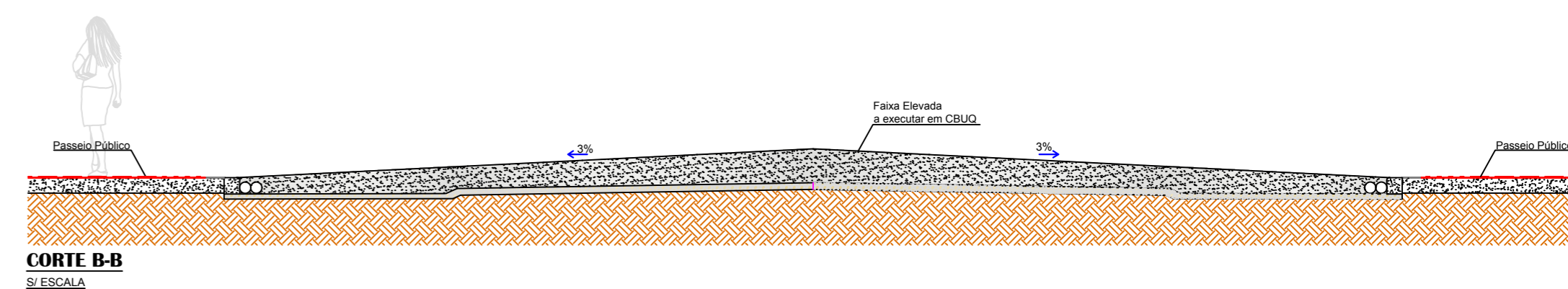
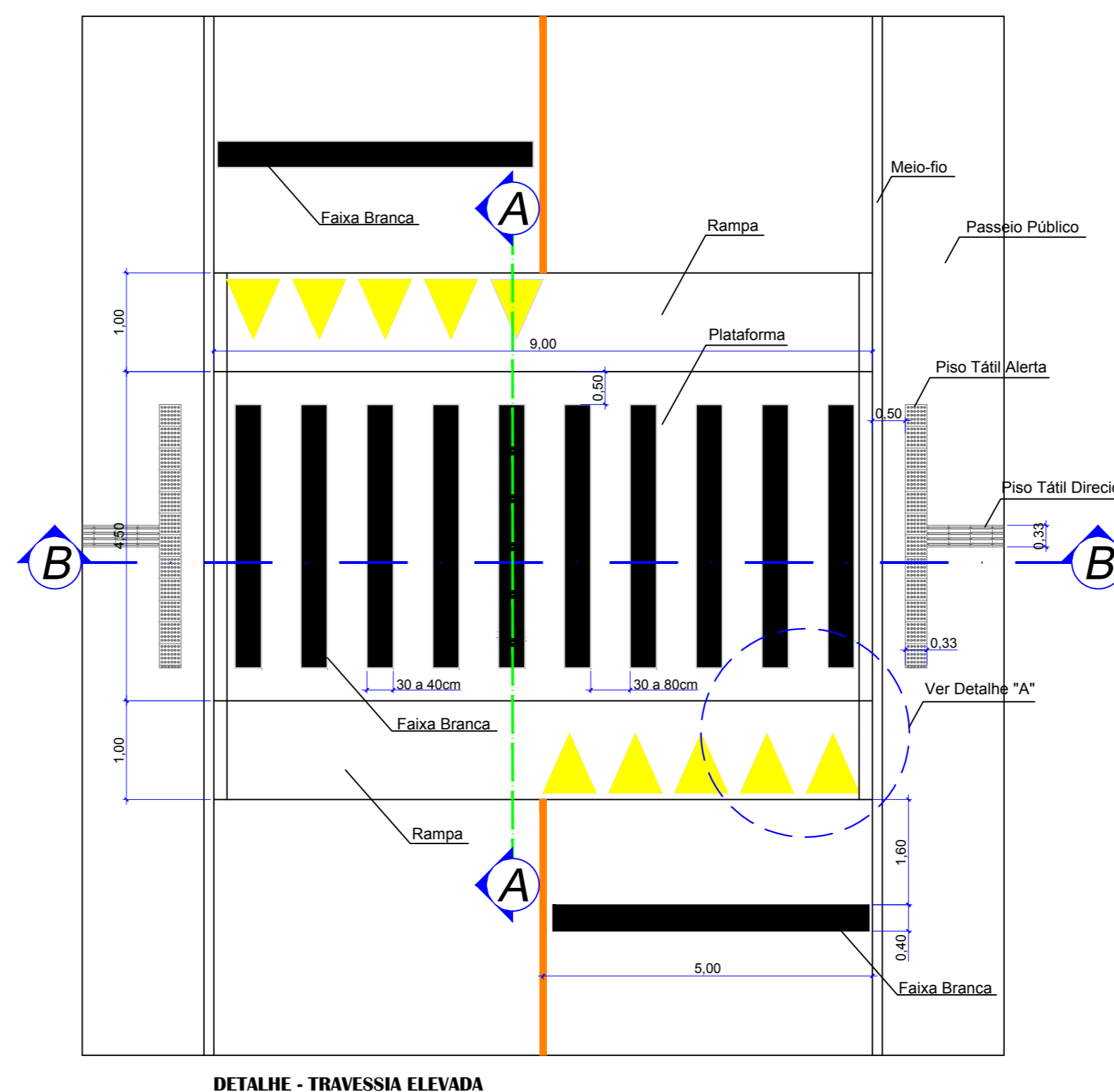
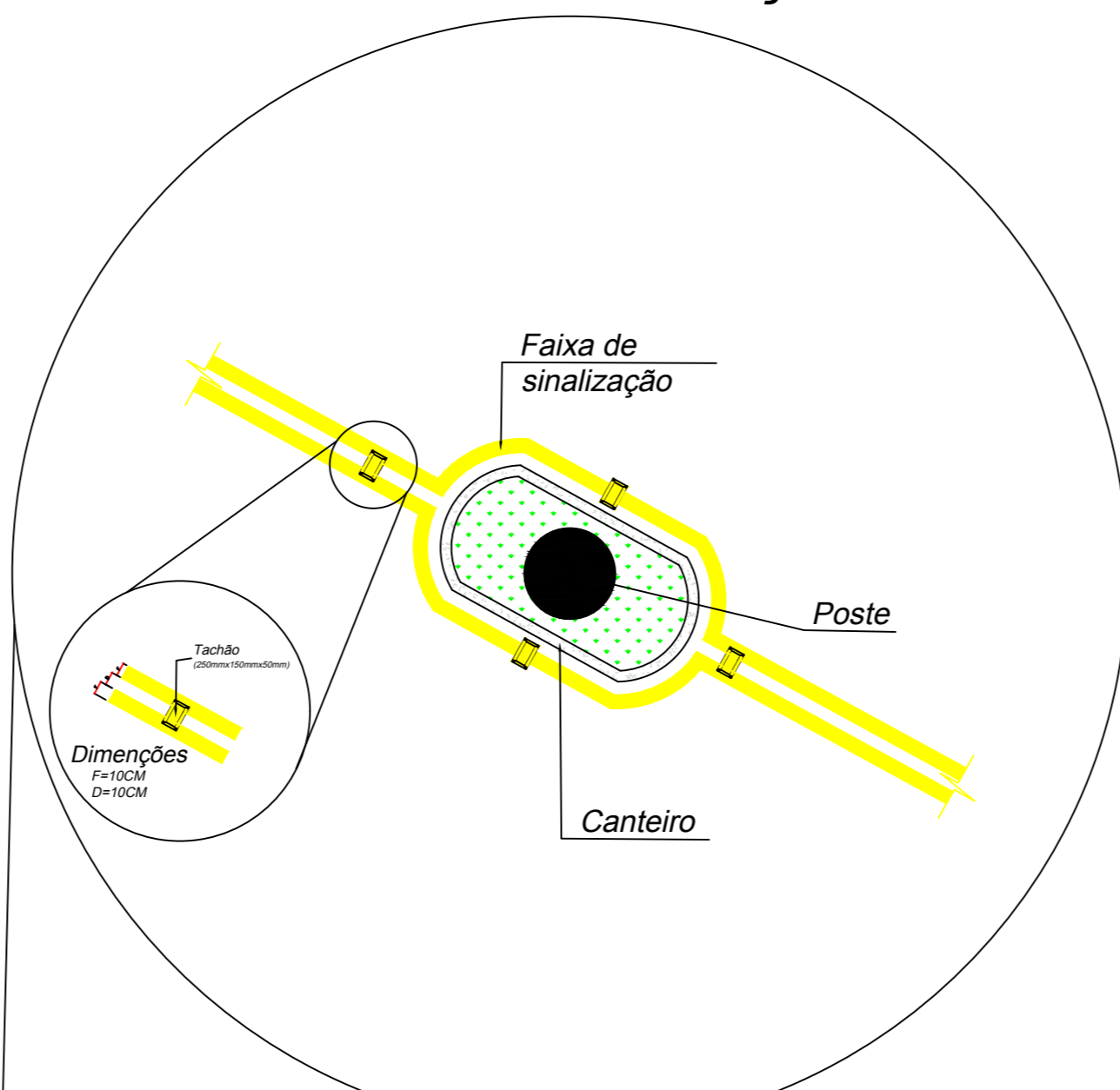

Detalhe 2 - CT - Canteiro de Travessia

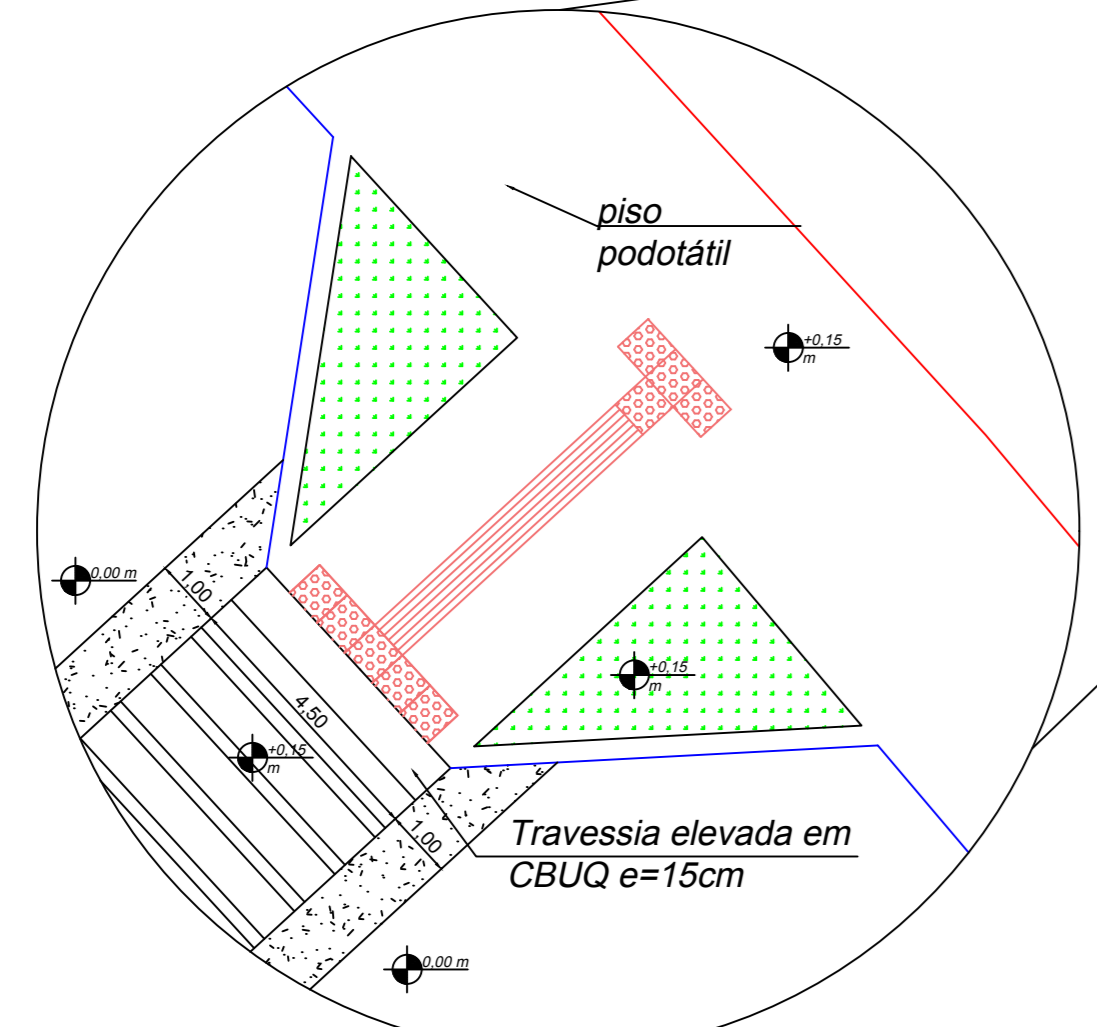

Detalhe 2 - CT - Canteiro de Travessia

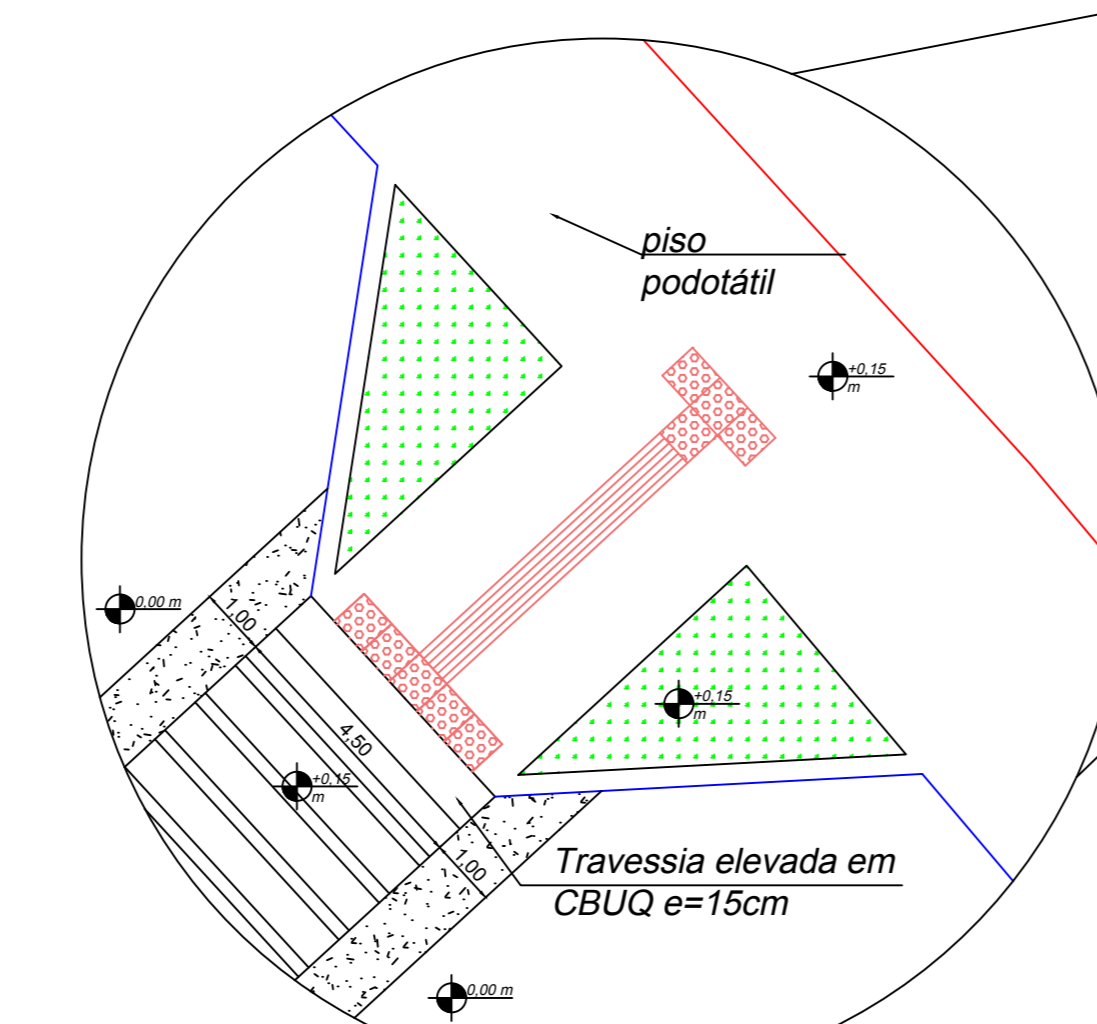

Detalhe 2 - CT - Canteiro de Travessia

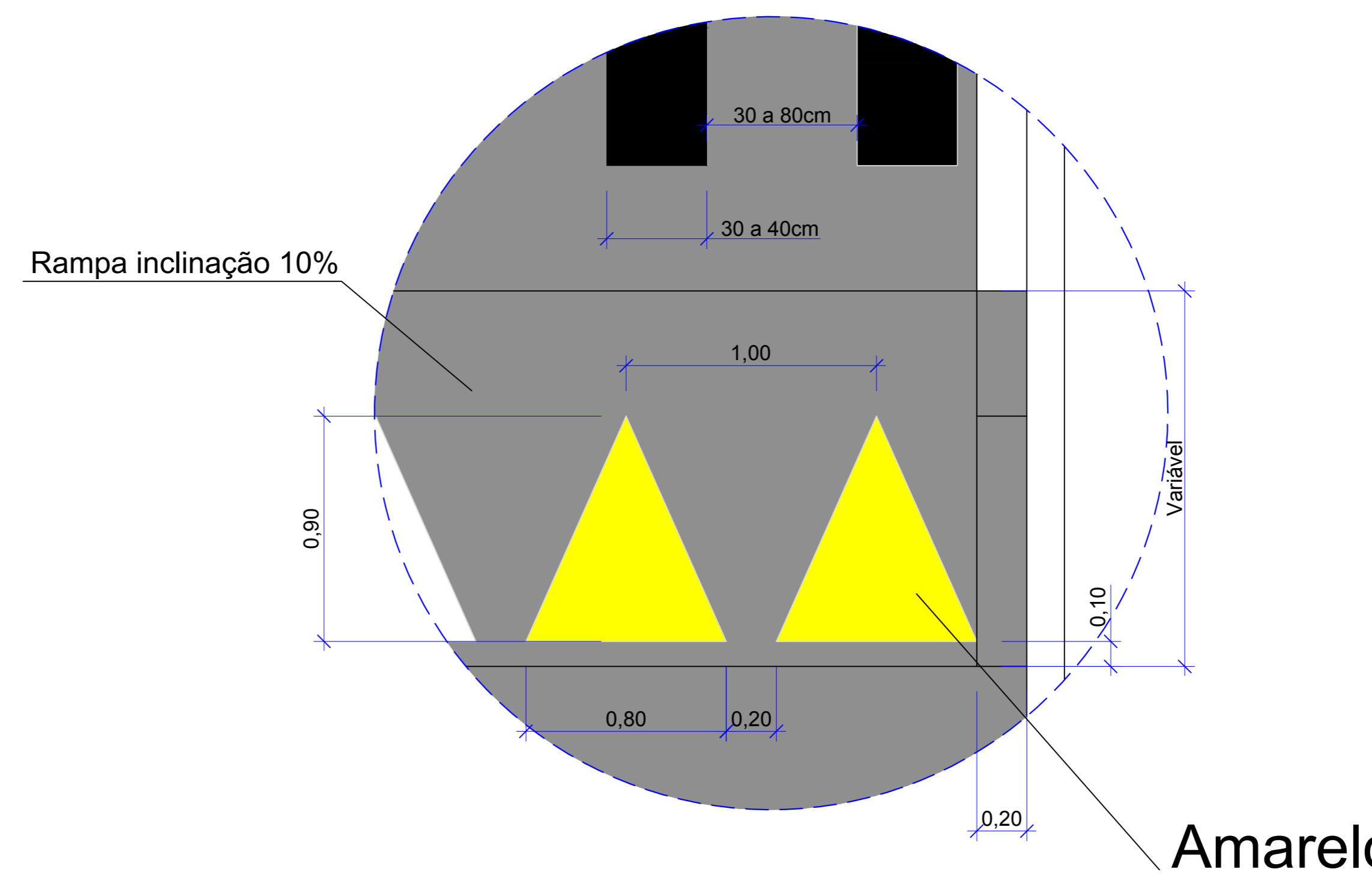
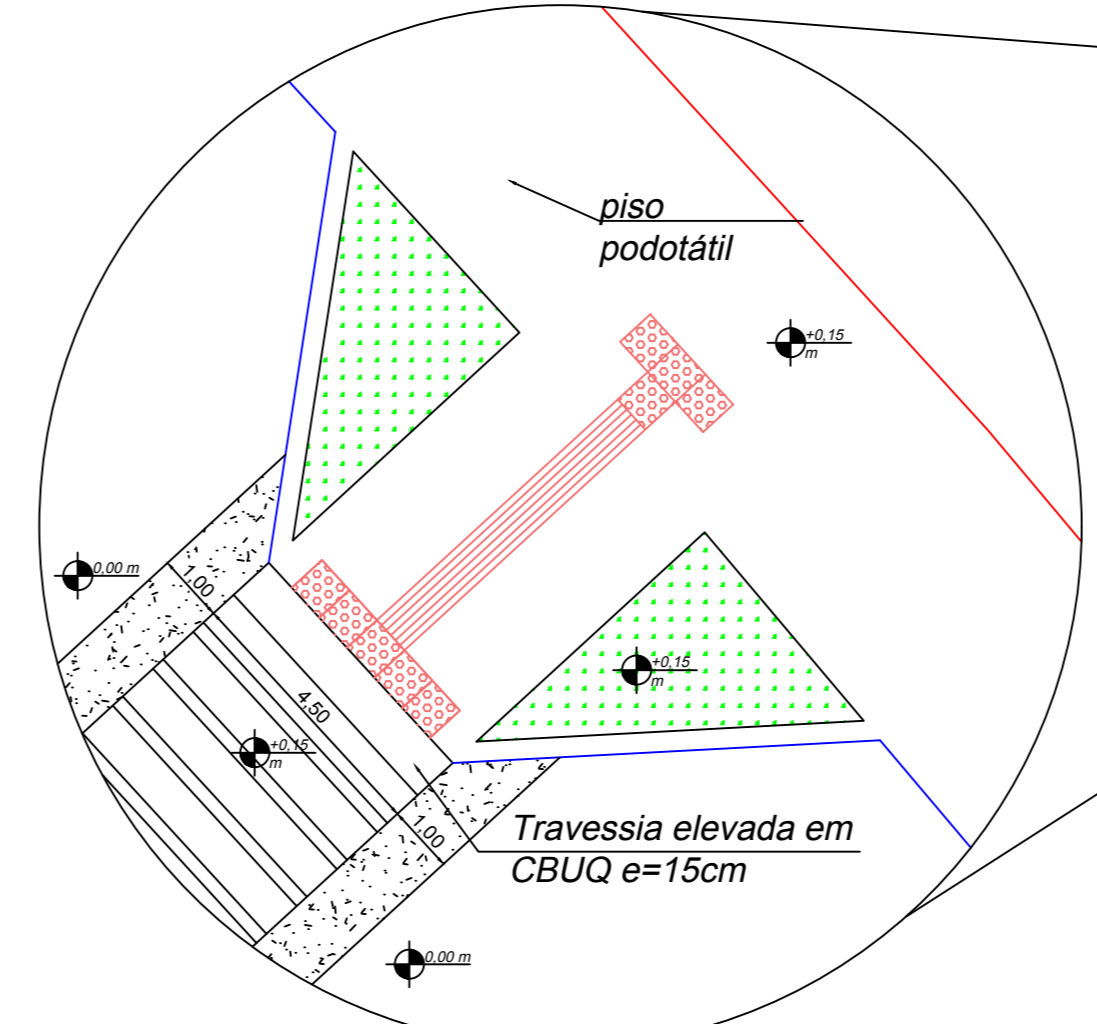

Tachão

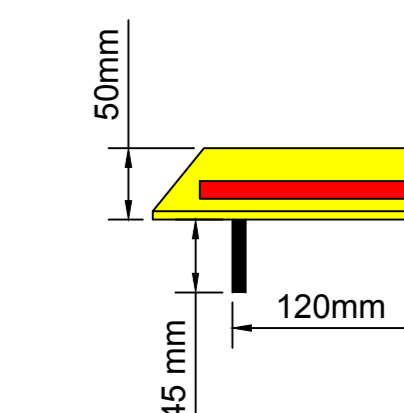
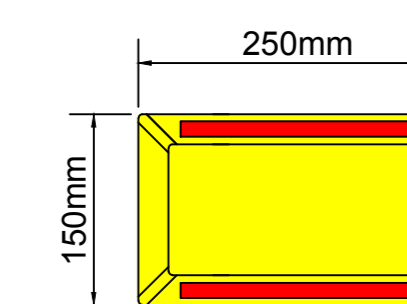

Elemento refletivo

- Corpo na cor amarela ou branca, de acordo com a marca viária que complementa
- Cor elemento refletivo
- Branca - para ordenar fluxos de mesmo sentido
- Amarela - para ordenar fluxo de sentidos opostos
- Vermelha - em rodovias, de pista simples, duplo sentido de circulação, podem ser utilizadas unidades refletivas na cor vermelha, junto ao bordo da pista ou acostamento do sentido oposto

Quantidade total: 264 Tachões.

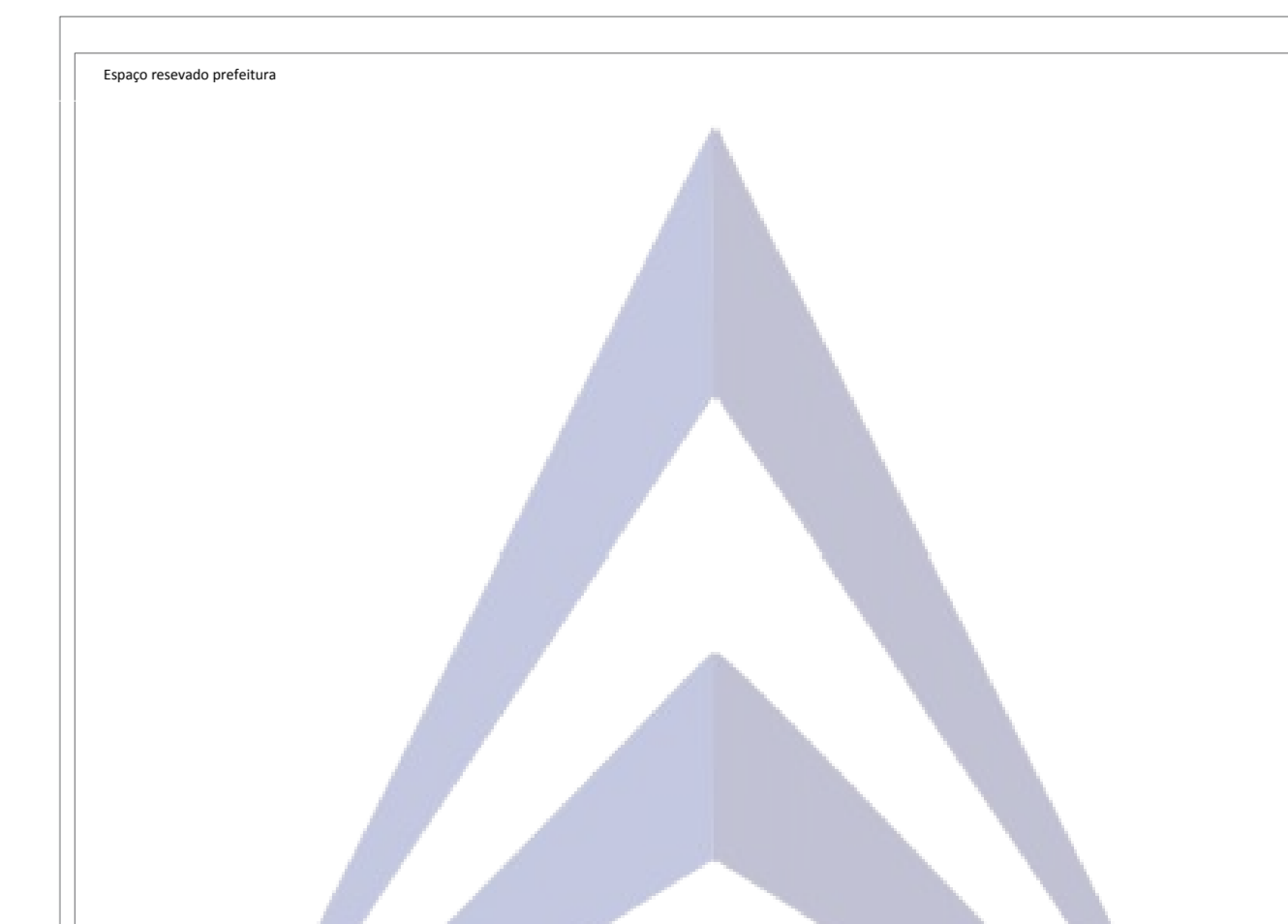

CONTRATANTE: Prefeitura Municipal de Celso Ramos - SC

RESPONSÁVEL TÉCNICO: Eng. Civil Especialista Dutra CREA-SC: 139.201-9

Revitalização Avenida Dom Daniel Hostin

Prefeitura Municipal de Celso Ramos - SC

Av. Dom Daniel Hostin

Planta Baixa, Detalhamento

PROJETO: 01/09/2022

INDICADA: 0922

552,62m

Engenharia ECG

PRANCHA A0-07